



**BMT**  
EXPORT

D 800 - 1000 - 1200 F



D 1000 - 1200 F



D 800 F

SCARICO IDRAULICO FRONTALE  
DESCHARGEMENT HYDRAULIQUE FRONTAL  
HYDRAULIC FRONTAL TIPPING  
DESCARGA HIDRAULICA FRONTAL

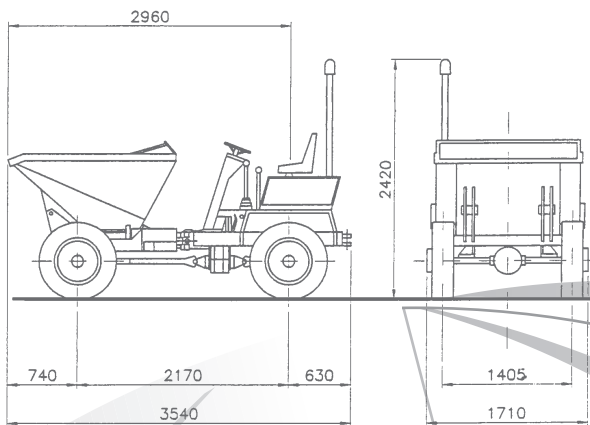

# D 800 - 1000 - 1200 F

**CARATTERISTICHE TECNICHE**  
**DONNEES TECHNIQUES**  
**SPECIFICATIONS**  
**CARACTERISTICAS TECNICAS**

	D 800 F	D 1000 F	D 1200 F
<b>CAPACITA' DELLA BENNA - CAPACITE' DE LA BENNE - SKIP CAPACITIES - CAPACIDAD DE LA TOLVA</b>			
<b>A RASO</b> A RAS <b>STRUCK</b> NIVEL DE AGUA	<b>800 ltr.</b>	<b>1.000 ltr.</b>	<b>1.200 ltr.</b>
<b>A COLMO</b> COMBLEE <b>HEAPED</b> COLMADA	<b>1.000 ltr.</b>	<b>1.200 ltr.</b>	<b>1.500 ltr.</b>
<b>PORTATA</b> PORTEE <b>MAX PAYLOAD</b> CARGA UTIL	<b>1.500 Kg</b>	<b>2.500 Kg</b>	<b>3.000 Kg</b>
<b>PESO A VUOTO</b> POIDS A VIDE <b>UNLOADED WEIGHT</b> PESO EN VACIO	<b>1.070 Kg</b>	<b>1.390 Kg</b>	<b>1.700 Kg</b>
<b>MOTORE DIESEL / HATZ AVV. ELETTRICO</b> MOTEUR DIESEL / HATZ DEMARRAGE ELECTRIQUE <b>DIESEL ENGINE / HATZ ELECTRIC START</b> MOTOR DIESEL / HATZ ARRANQUE ELECTRICO	<b>1D81</b>	<b>2G40</b>	<b>2G40</b>
<b>POTENZA</b> PUISSANCE <b>POWER</b> POTENCIA MOTOR	<b>HP 14,3</b>	<b>HP 23</b>	<b>HP 23</b>
<b>Nr. CILINDRI</b> Nr. CYLINDRES <b>Nr CYLINDERS</b> Nr. CILINDROS	<b>1</b>	<b>2</b>	<b>2</b>
<b>TRASMISSIONE</b> TRANSMISSION <b>MECHANICAL</b> TRANSMISION	<b>MECCANICA</b> MECANIQUE <b>TRANSMISSION</b> MECANICA MEDIANTE CARDAN	<b>.</b>	<b>.</b>
<b>MARCE AVANTI / RETRO</b> VITESSE AV/AR <b>FORWARD / REVERSE GEARS</b> VELOCIDADES ADELANTE / ATRAS	<b>4/4</b>	<b>4/4</b>	<b>4/4</b>
<b>FRIZIONE MONODISCO A SECCO</b> EMBAYAGE MONODISQUE A SEC <b>SINGLE DRY PLATE CLUTCH</b> EMBRAGUE MONODISCO EN SECO	<b>.</b>	<b>.</b>	<b>.</b>
<b>VELOCITA' MAX</b> VITESSE MAX <b>MAX SPEED</b> VELOCIDAD MAX	<b>25 Km/h</b>	<b>25 Km/h</b>	<b>25 Km/h</b>
<b>FRENI</b> FREINS <b>BRAKES</b> FRENOS	<b>IDRAULICI SULLE 4 RUOTE</b> HYDRAULIQUES SUR LES 4 ROUES <b>4 WHEELS HYDRAULIC FOOTBRAKES</b> HIDRAULICOS SOBRE LAS 4 RUEDAS	<b>.</b>	<b>.</b>
<b>RUOTE MOTRICI</b> ROUES MOTRICES <b>WHEELS DRIVE</b> RUEDAS MOTRICES	<b>4</b>	<b>4</b>	<b>4</b>
<b>PNEUMATICI</b> PNEUS <b>TYRES</b> NEUMATICOS	<b>6,00-16 pr.</b>	<b>7,50 - 16</b>	<b>7,50 - 16</b>



**BMT**  
EXPORT

Made in Italy